



KLIP-LOK® 770



Design and Installation Guide



LYSAGHT KLIP-LOK® 770 is a new generation widest-cover concealed-fixed cladding. Made of high tensile steel of 550 MPa yield strength, it spans widest, with better uplift performance than all available comparable profiles. Visually, you get a bold rib that makes a strong statement rising from the flat pans with two stiffeners in between the rib. Our extensive research shows that thermal expansion and contraction can be controlled better using a concealed fix system. Since the effect is on the longitudinal direction, wider coverage of LYSAGHT KLIP-LOK® 770 provides the best alternative. It is well suited to both general environment and coastal environment. The profile is fixed on a specially designed clip known as KL-77, manufactured from high tensile steel base and designed tower to withstand high wind pressure. This provides accuracy, economy and ease during the installation and makes it a superior product designed to last long.

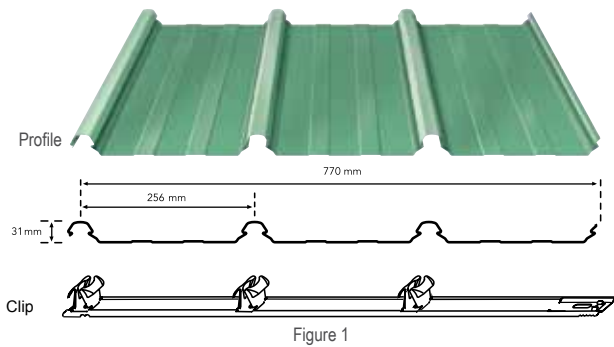

Figure 1

Profile

LYSAGHT KLIP-LOK® 770 is 770 mm wide profile with nominal 31 mm deep ribs and pitch of 256mm. The specially designed shape of the profile combined with the high tensile property of the base steel help in better interlocking of the panels on lateral ends. The profile is fixed on a specially designed clip (KL-77) to the base purlin, avoiding any external screw on the roof, making it watertight and leak proof in comparison to any conventional screw down profile (Refer figure 1).

Material Specifications:

ZINCALUME® steel resin coated, minimum metallic coating mass is AZ150 (150g/m²), minimum yield strengths of G550 (550MPa) complies with AS1397 or IS15961.

COLORBOND® XRW is pre-painted steel for exterior roofing and walling. It is the most widely used, minimum metallic coating mass is AZ150 (150g/m²), minimum yield strengths is G550 (550 MPa), Super Durable Polyester exterior paint system, total 25um DFT on topside and 10um DFT on reverse side complying with AS/NZS 2728- type 4 or IS15965- class 3.

COLORBOND® Ultra is pre-painted steel for severe coastal or industrial environments (closer to source), minimum metallic coating mass is AZ200 (200g/m²), minimum yield strengths is G550 (550MPa), Super

Durable Polyester exterior paint system, total 25um DFT on topside and 15um DFT on reverse side complying with AS/NZS 2728- type 4 or IS15965- class 3.

(Please contact Tata BlueScope steel office for COLORBOND® spectrum series (metallic finish) and COLORBOND® XPD (PVDF) specification)

COLORBOND® steel with THERMATECH™ Technology

COLORBOND® steel with THERMATECH™ technology reflects more of the sun's heat, allowing both roofs and buildings stay cooler in summer. In moderate to hot climates, compared to roofing materials of similar colour with low solar reflectance, COLORBOND® steel with THERMATECH™ can reduce annual cooling and energy consumption by up to 15%*and also reduces peak roof temperature by up to 6°C**.

Lengths

On site roll-forming from ridge to eave, i.e. single jointless sheet or custom cut.

Masses

KLIP-LOK® 770				
BMT*	TCT*	Product	kg/m	kg/m ²
0.42	0.47	ZINCALUME® steel	3.25	4.22
0.42	0.47	COLORBOND® steel	3.30	4.29
0.45	0.50	ZINCALUME® steel	3.47	4.50
0.45	0.50	COLORBOND® steel	3.53	4.58
0.60	0.65	ZINCALUME® steel	4.58	5.94
0.60	0.65	COLORBOND® steel	4.63	6.02

*Dimensions are in mm

Tolerances

Length: 0 mm, - 15 mm

Width: + 4 mm, - 4 mm

Roofs:

C_{pe} = - 1.20 (internal cladding spans)

C_{pe} = - 2.0 (single and end cladding spans)

C_{pi} = + 0.2

Maximum Support Spacing (in millimetres)

The maximum recommended support spacings are based on tests conducted in accordance with AS1562.1-1992, AS4040.1-1992 & AS4040.2 1992. Roof spans consider both resistance to wind pressure and light roof traffic (traffic arising from incidental maintenance). Wall spans consider resistance to wind pressure only.

The pressure considered (in accordance with IS 875.3) is based on buildings up to 10m high, Zone 3 (Basic wind speed $V_b = 47\text{m/s}$), Class A, Terrain category 3, $k_1 = 1.0$, $k_2 = 0.91$, $k_3 = 1.0$, with the following assumptions made;

Maximum Support Spacings (mm)		
Type of span	Total Coated Thickness (mm)	
	0.47	0.50
Roofs		
Single Span	1000	1200
End Span	1000	1300
Internal Span	1300	1500
Unstiffened eaves overhang		
Stiffened eaves overhang		

• Tables are based on supports of 1 mm BMT
 • Please contact Tata BlueScope Steel office before adopting for design
 • For wall cladding, please contact Tata BlueScope Steel Technical team

Span Types:

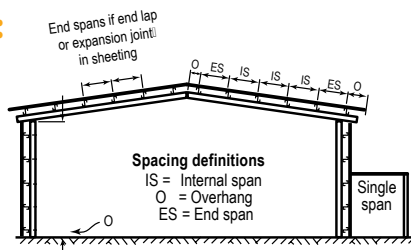

Maximum roof lengths for drainage measured from ridge to gutter (in metres)

Penetrations will alter the flow of water on a roof. For

Accurate testing

LYSAGHT KLIP-LOK® profile has been tested with the latest pressurised air chamber for modelling wind pressures (Refer photograph). The wind pressure capacity table are obtained from our direct – pressure test rig which accurately reproduces the wind conditions experienced in the field. It does not uses air bags and applies pressure uniformly over the entire profile including ribs. (Refer figure A).

Older air bag method used by others distribute pressure unevenly, so that air bags can produce misleading results and inflated strengths as it does not allow pressure to be applied to ribs (Refer figure B).

assistance in design of roofs with penetrations, please seek advice from your nearest Tata BlueScope Steel office.

Maximum Roof Run (m) as based on CSIRO* Formula							
	Rainfall Intensity mm/hr	Roof Slope					
		1°	2°	3°	5°	7.5°	10°
KLIP-LOK® 770 Flow Area = 4902 m2	100	258	321	377	469	559	642
	150	172	214	251	312	373	428
	200	129	161	188	234	279	321
	250	103	128	151	187	224	257
	300	86	107	126	156	186	214
	400	65	80	94	117	140	161
500	52	64	75	94	112	128	

*Commonwealth Scientific & Industrial Research Organisation

Limit States Wind Pressures

LYSAGHT KLIP-LOK® 770 offers the full benefits of the latest methods for modelling wind pressures.

The wind pressure capacity table is determined by full scale tests conducted at BlueScope Steel's NATA-registered testing laboratory, using the direct pressure-testing rig. Testing was conducted in accordance with AS 1562.1-1992 Design and Installation of Sheet Roof and Wall Cladding-Metal and AS 4040.2-1992 Resistance to Wind Pressure for Non-cyclonic Regions.

The pressure capacities for serviceability are based on a deflection limit of $(\text{span}/120) + (\text{maximum fastener pitch}/30)$. The pressure capacities for strength have been determined by testing the cladding to failure (ultimate capacity). These pressures are applicable when the cladding is fixed to a minimum of 1.0 mm, G550 steel purlin. For material less than 1.0 mm thickness, seek advice from your nearest Tata BlueScope Steel office.

Adverse Conditions

If this product is to be used in marine, severe industrial, or unusually corrosive environments, ask for advice from your nearest Tata BlueScope Steel Office.

Figure A Accurate Testing Method

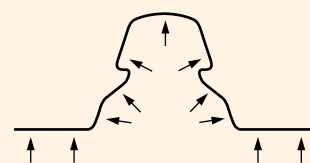
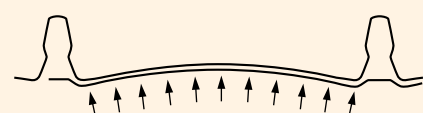

Figure B Industry Testing - Air Bag Method



KLIP-LOK® 770: Limit state wind pressure capacities (KPa)												
Span Type	Limit State	Span (mm)										
		900	1200	1500	1800	2100	2400	2700	3000	3300	3600	3900
KLIP-LOK® 770 - 0.42 mm Base Metal Thickness (0.47 mm Total Coated Thickness)												
SINGLE	Serviceability	1.63	1.32	1.03	0.77	0.56	0.41	0.31	0.23	0.18	-	-
	Strength*	3.05	2.56	2.09	1.68	1.36	1.14	1.01	0.93	0.88	-	-
END	Serviceability	1.43	1.43	1.36	1.19	0.96	0.74	0.58	0.47	0.39	0.34	-
	Strength*	2.86	2.34	1.91	1.62	1.44	1.31	1.18	1.03	0.88	0.72	-
INTERNAL	Serviceability	1.57	1.40	1.23	1.07	0.93	0.81	0.70	0.61	0.53	0.45	0.38
	Strength*	2.51	2.26	2.01	1.78	1.58	1.40	1.24	1.11	0.99	0.89	0.78
KLIP-LOK® 770 - 0.45 mm Base Metal Thickness (0.50 mm Total Coated Thickness)												
SINGLE	Serviceability	2.17	1.81	1.46	1.14	0.88	0.68	0.52	0.40	0.30	-	-
	Strength*	3.68	3.06	2.47	1.98	1.62	1.42	1.35	1.35	1.35	-	-
END	Serviceability	2.20	1.84	1.51	1.23	1.00	1.82	0.67	0.55	0.45	0.35	-
	Strength*	3.36	2.87	2.41	2.02	1.69	1.42	1.20	1.02	0.87	0.73	-
INTERNAL	Serviceability	2.00	1.96	1.89	1.74	1.50	1.22	0.95	0.74	0.67	0.67	0.67
	Strength*	3.10	2.75	2.43	2.13	1.88	1.67	1.49	1.35	1.23	1.14	1.05

* A capacity reduction factor of $\phi=0.9$ has been applied to strength capacities. Supports must be not less than 1 mm BMT.
 * Please contact Tata BlueScope Steel office before adopting for design.
 * Non standard thickness, sizes & colours are also available on special request.
 The above data has been derived from the tests conducted at our research centre and reproduction of the same in any form is strictly prohibited.

Installation

Preparation

Before starting work ensure that:

- The support for your cladding is truly in the same plane
- The minimum roof slope conforms to our recommendation
- The overhang of sheets from the top and bottom supports don't exceed our recommendation

Make necessary adjustments before you start laying sheets as per our recommendations.

Orientation of Sheet before Lifting

Consider which end of the building is best to start from. For maximum weather - tightness, start laying sheets from the end of the building that will be downwind of the worst - anticipated or prevailing weather (Refer figure 1).

It is much easier and safer to turn sheets on the ground than up on the roof. Before lifting sheets onto the roof, check that they are the correct way up and the overlapping side is towards the edge of the roof from which installation will start.

Place bundles of sheet over or near firm support, not at mid span of the roof members.

Starting method 1. Cut the 1st clip 25mm from the centre of the second tower (as shown). The first tower on the cut clip locates in the 1st rib of the first sheet (Figure 2) but you must fix two clips at the start.

Figure 1

Lay sheets towards prevailing weather

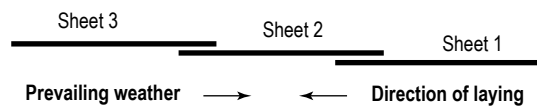
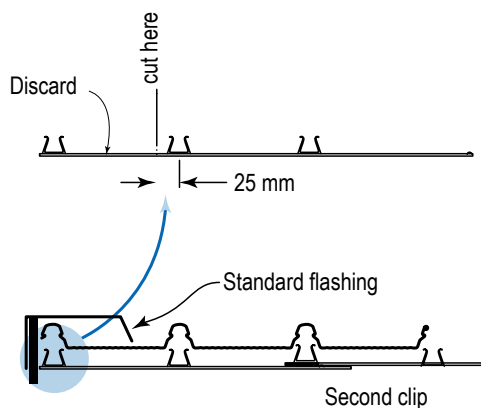

Figure 2

Alternative methods forfix clips.

KLIP-LOK® 770: Starting method 1



KLIP-LOK® 770: Starting method 2

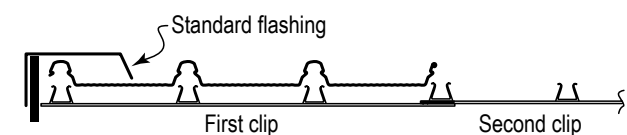

Starting method 2. The first tower on the first clip locates in the first rib of the first sheet (Figure 2). The clip fixes the edge of the first sheet.

Steps for Installation

1. Lay wire mesh or chicken wire mesh on the purlins and weld or screw the wire mesh to each purlin.
2. Position the first clips on each purlin by placing onto the purlin nearest to the gutter (Refer figure 3).
3. Fix the first clip on the purlin so that they point in the direction of laying. Ensure the clip is 90° to the edge of the sheet.
4. Align the clips with the spacer using a string line (or the first sheet as a straight edge) to align the clips as you fix a clip to each purlin working towards the high end of the roof.
5. Drive hex head screw through the top of the clip, into the purlin.
6. Work along the edge of the gutter, ensuring it aligns correctly at its end in relation to the gutter and ridge (or parapet or transverse wall).
7. Measure the distance from the gutter end of the sheet to the fascia or purlin.
8. Position the first sheet so that the overhangs are of the desired amount (usually 50 mm) to the gutter. It is important to ensure this first sheet is placed squarely to adjacent edges (Refer figure 4).
9. Engage the sheet with clips using vertical foot pressure on all the ribs over each clip (Refer figure 5).
10. Fix the next row of clips, one to each support with the slots and tabs engaged. Be sure the clip is 90° to the edge of the sheet (Refer figure 6).
11. As before, place the next sheet over its clips also engaging the edge of the preceding sheet.
12. Accurately position the sheet so that it overhangs the desired amount into the gutter. It is important that you keep the gutter- end of all sheets in a straight line.
13. Fully engage the two sheets along the overlapping rib. You can do this by walking along the full length of the sheet with one foot in the centre pan of the previous sheet and the other foot applying vertical pressure to the top of the interlocking ribs at regular intervals. It is important that you don't walk in the unsupported pan besides the overlap. A rubber mallet may help engagement of laps on

Figure 3

Fix the first row of clip. Fix the next (and subsequent) clips and sheets.

KLIP-LOK® 700

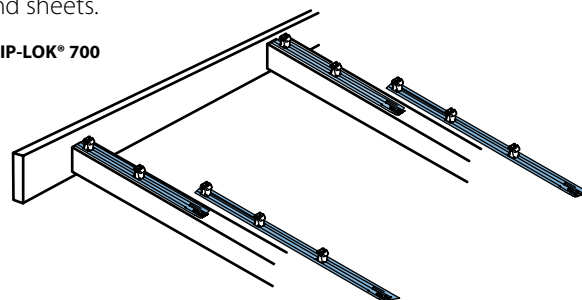

Figure 4

Placing the first sheet.

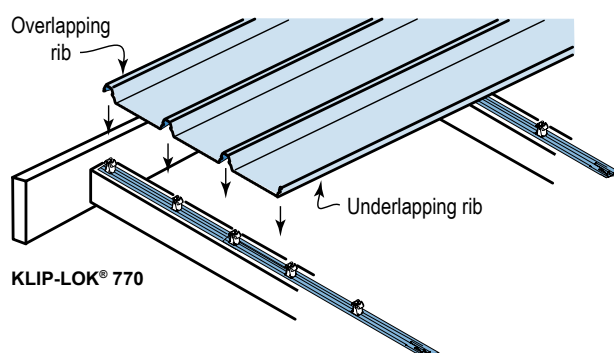

Figure 5

Engaging the lapping ribs.

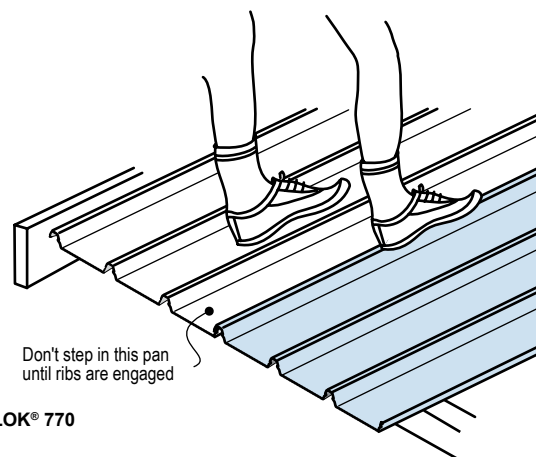
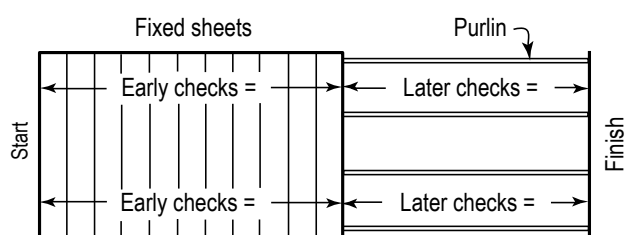

Figure 6

Check alignment occasionally.



long spans (Refer figure 5).

14. Similarly, engage all the clips by applying vertical footpressure to the top of the other ribs over each clip. It is essential that the sheets interlock completely. It is important that your weight is fully on the sheet you are installing.

Check alignment occasionally

Occasionally check that the sheets are still parallel with the first sheet, by taking two measurements across the width of the fixed cladding.

At about half way through the job, perform a similar check but take the measurements from the finishing line to aim for the final sheet to be parallel with the end of the roof. If the measurements are not close enough, lay subsequent sheets slightly out of parallel to gradually correct the error (Refer figure 7). To allow this to happen, flatten the tabs on the base of subsequent clips - the slot in the clip will allow the clips to be fixed out of standard pitch.

Fix the last sheet

If the final space is less than the full width of a sheet, you can cut a sheet along its length and shorten the clips as appropriate.

Installing KLIP-LOK® 770 wall

The installation procedure for walls is similar to that described for roofs. To engage clips, use a rubber mallet (instead of foot pressure). To prevent KLIP-LOK® 770 from sliding downward in the fixing clips, you should pierce-fix through each sheet under the flashing or capping, along the top of the sheets.

Maintenance

Washing all external walls regularly will aid in attaining optimum product life. Areas not cleaned by natural rainfall (such as top portion of walls sheltered by eaves) should be washed down every six months.

While walking on roofs, keep your weight evenly distributed over the soles of both feet to avoid concentrating your weight on either heels or toes. Always wear smooth soft-soled shoes; avoid ribbed soles that pick up and hold small stones, swarf and other objects.

Storage and Handling

Keep the product dry and clear off the ground. If stacked or bundled product becomes wet, separate it and wipe

it with a clean cloth to dry thoroughly. Handle materials carefully to avoid damage. Do not drag materials over rough surfaces or each other, do not drag tools over material and protect it from swarf.

Metal and Timber Compatibility

Lead, copper, free carbon, stainless steel and green or some chemically-treated timber are not compatible with this product. Don't allow any contact of the product with these materials, nor discharge of rainwater from them onto the product. Supporting members should be coated to avoid problems with underside condensation. If there are doubts about the compatibility of other products being used, ask for advice from your nearest Tata BlueScope Steel office.

Cutting

For cutting thin metal on site, we recommend a circular saw with a metal-cutting blade because it produces fewer damaging hot metal particles and leaves less resultant burr than does a carborundum disc.

Cut materials over the ground and not over other materials. Sweep all metallic swarf and other debris from roof areas and gutters at the end of each day and at the completion of the installation. Failure to do so can lead to surface staining when the metal particles rust.

Turn up/down Tools

On all roofs of pitches less than 15°, the high end of all sheets must be turned up to stop water from being driven under the flashing and into the building. Similarly, the pans at the gutter end must be turned down to stop water running back along the underside of the sheets.

Fasteners

All fasteners shall conform to Australian Standard AS3566-2002 Class 3 (minimum) for external application. Where insulation is to be installed, you may need to increase the length of the screws given below, depending on the density and thickness of the insulation. When the screw is properly tightened:

- **Into metal:** there should be at least three threads protruding past the support you are fixing to, but the Shankguard must not reach that support
- **Into timber:** the screw must penetrate the timber upto the same amount that the recommended screw would do if there were no insulation

Fasteners without insulation				
Support Details	Numbers of Fasteners		Clips per m2	Clip Fixing Roof & Wall Application
	Per Sheet/support	Per m2		
Steel up to 0.75 mm BMT	3	4*	1.5*	12-14 x 30, Metal Tekes, Hex Head to steel 12-11 x 40, Type 17, Hex Head to Softwood 12-11 x 25, Type 17, Hex Head to Hardwood (No Sealing washer with screw)
Steel > 0.75 mm BMT up to 3 mm BMT				
Timber - Softwood				
Timber - Hardwood				

Note:
 1. All screws are self drilling, self tapping without EPDM sealing washer
 2. The number of screws per support are per m2 and are only for guidance, based on support spaced at 1 m and wall 0.6m
 3. * - the screw quantity is based on an average number of screws
 4. Please refer to the above data for guidance purpose only. You may contact Tata BlueScope Steel office for further information

Sealed Joints

For sealed joints, use screws or rivets and neutral-cure silicone sealant branded as suitable for use with COLORBOND® steel and ZINCALUME® steel.

Non-Cyclonic Areas

The information in this brochure is suitable for use only in areas where a tropical cyclone is unlikely to occur. Ask for advice from your nearest Tata BlueScope Steel office on designs to be used in cyclonic areas.





Global Excellence since 1857

Benefits

- Wide cover concealed fixed cladding system with no exposed fasteners for weather tight roofs
- Bold ribs make strong visual appeal
- Fixed on specially designed clip which holds uplift pressure on the base purlin much easily and allows thermal expansion and contraction
- Suitable for curve shape buildings
- Economical and quick to install
- Available with onsite mobile roll forming for even, long, uninterrupted and low roof pitch
- Appealing architectural appearance and multiple colour choices enable different design features
- Manufactured from G550 COLORBOND® steel or ZINCALUME® steel

Product Descriptions

- All descriptions, specifications, illustrations, drawings, data, dimensions and weights contained in this catalogue, all technical literature and websites containing information from LYSAGHT® are approximations only. They are intended by LYSAGHT® to be a general description for information and identification purposes and do not create a sale by description. LYSAGHT® reserves the right at any time to:
 - (a) Supply goods with such minor modifications from its drawings and specifications as it sees fit
 - (b) Alter specifications shown in its promotional literature to reflect changes made after the date of such publication

Disclaimer, Warranties and Limitation of Liability

- This publication is intended to be an aid for all trades and professionals involved with specifying and installing LYSAGHT® products and not to be a substitute for professional judgement
- Terms and conditions of sale available at local LYSAGHT® sales offices
- Except to the extent to which liability may not lawfully be excluded or limited, Tata BlueScope Steel will not be under or incur any liability to you for any direct or indirect loss or damage (including, without limitation, consequential loss or damage such as loss of profit or anticipated profit, loss of use, damage to goodwill and loss due to delay) however caused (including, without limitation, breach of contract, negligence and/or breach of statute), which you may suffer or incur in connection with this publication



Standard Colour Range

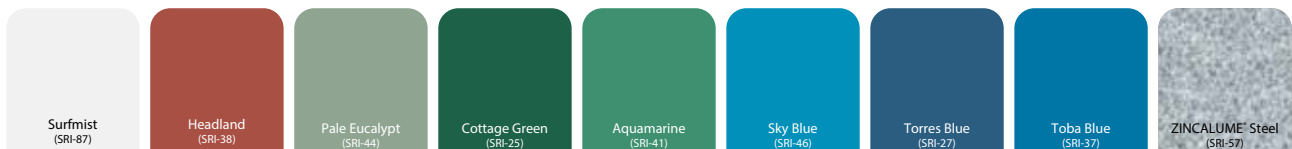

The above colours are only for illustrative purpose and actual colours may vary.



Email us at : lysaght@tatabluescopesteel.com



Note:
©2019 Tata BlueScope Steel Pvt. Ltd. All rights reserved. No part of this brochure may be reproduced or transmitted in any form or by any means, electronic or mechanical including photocopy, recording, or any information storage and retrieval system, without permission in writing from Tata BlueScope Steel Pvt. Ltd.. All brand names mentioned in this brochure are registered trademarks of BlueScope Steel Limited under license to Tata BlueScope Steel Pvt. Ltd.*

Tata BlueScope Steel Pvt. Ltd. CIN: U45209PN2005PTC020270
Regd. Office: The Metropolitan, 4th Floor, Final PlotNo. 27,
Survey No. 21, Wakdewadi, Shivaji Nagar, Pune - 411005. INDIA.
Tel: +91 20 6621 8000
Website: www.tatabluescopesteel.com