



LOK-KLIP™



Design and Installation Guide



LOK-KLIP™ and KLIP-LOK® 700

The new LYSAGHT® LOK-KLIP™ system provides installers with a quick and easy end joint/expansion joint solution between overlapping sheets of KLIP-LOK® 700. The LOK-KLIP™ system comprises of a fully engineered ZINCALUME® steel bracket and a custom shaped weather resistant polyethylene foam weather strip. The LOK-KLIP™ bracket replicates the role of a standard concealed fix bracket and is secured to the ribs of the bottom sheet using standard roofing fasteners.



Background on thermal expansion

All metals expand and contract with changes in temperature. Although steel is by far the least affected of all the metals commonly used for roof and wall cladding, the changes in length experienced in very long runs of roofing are significant.

When a LOK-KLIP™ is used, the length of each individual sheet is necessarily shorter, thus reducing the impact of thermal movement.

LOK-KLIP™ is an expansion joint/lap joint hybrid

An expansion joint involves overlapping the ends of the upper sheets over the ends of the lower sheets. With LOK-KLIP™, no extra purlin is needed at the joint.

A weather strip provides protection from wind-blown rain and is made from closed cell polyethylene foam. It is used between the upper and lower sheets and laid in pairs, one either side of the LOK-KLIP™ bracket to provide a weather resistant barrier from wind driven rainwater. It also provides air flow to reduce likelihood of condensate build-up.

The LOK-KLIP™ bracket is a pressed metal component that saddles the rib of the KLIP-LOK® 700 roofing by engaging the “S” bends of the lower sheet and is clipped into place. The bracket is fixed to the lower sheet by fasteners through the pre-punched holes however this allows the upper sheet to move relative to the bracket due to thermal expansion.

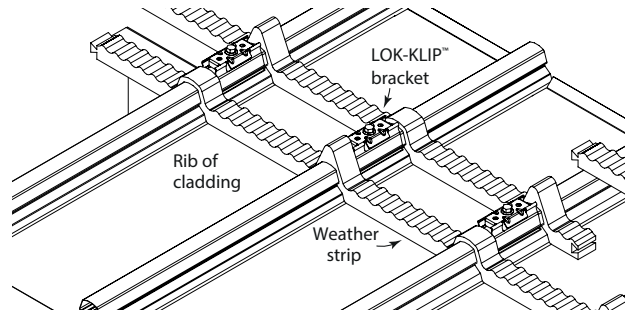

Figure 1: LOK-KLIP™ is comprised of brackets which are fixed to the ribs and two separate weather strips.

Testing

Made from Australian-made G550 AZ150 ZINCALUME® steel, LOK-KLIP™ is strong. LOK-KLIP™ has been tested for performance in wind uplift and weather-resistance at LYSAGHT®'s NATA-accredited materials science testing laboratory. This means you can be confident that LOK-KLIP™ will perform to specification when installed according to our design limitations and installation guidelines.



Figure 2: Wind uplift tests were performed to ensure LOK-KLIP™ clips meet the performance standards required.



Figure 3: Weather test rig is used to test weather-resistance by blowing simulated wind borne rain.

LOK-KLIP™ joint layout and fixing

This will allow normal concealed fastening at the support and thus allowing thermal movement to occur at the LOK-KLIP™. To install the LOK-KLIP™ bracket, locate each LOK-KLIP™ bracket as per Figure 5, then hand press to snap fit each LOK-KLIP™ bracket to the KLIP-LOK® 700 rib. (Figure 4a, 4b). For non-cyclonic areas, use a low torque setting on the drill to ensure the cladding is not stripped, secure through the top hole of the LOK-KLIP™ and also through the crest of the lower sheet. (Figure 4a) For cyclonic areas, use two fasteners by fixing through the sides of the LOK-KLIP™ bracket into the sides of the rib. (Figure 4b).

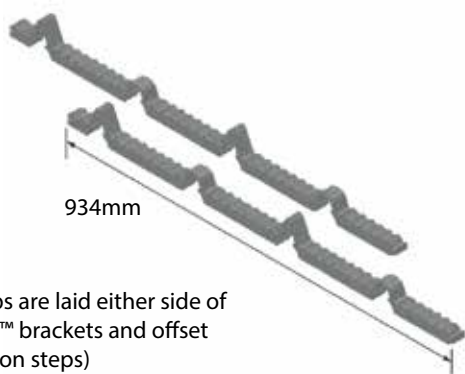

Figure 4: Weather strips are laid either side of the LOK-KLIP™ brackets and offset (see installation steps)

Figure 4a: Fixing of LOK-KLIP™ brackets to cladding

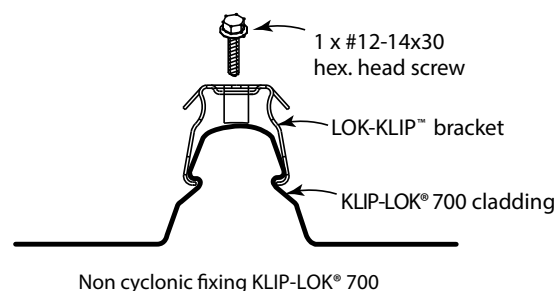

Figure 4b: Fixing of LOK-KLIP™ brackets to cladding

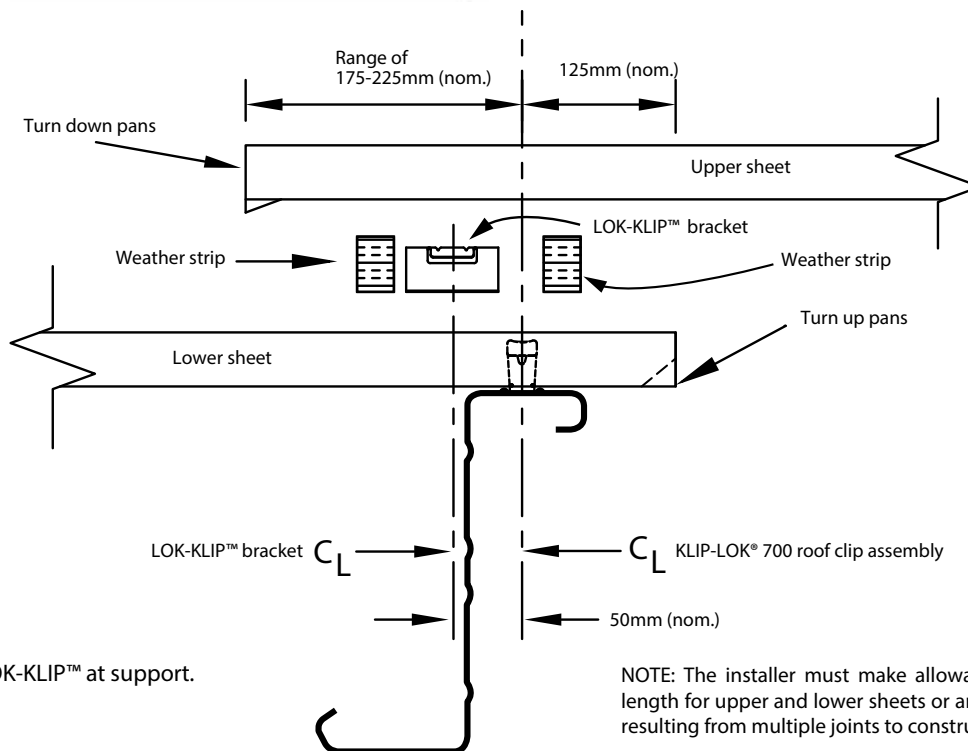
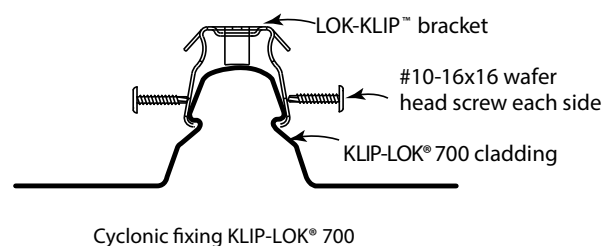

Figure 5
Details of LOK-KLIP™ at support.

NOTE: The installer must make allowance for added sheet length for upper and lower sheets or any intermediate sheet resulting from multiple joints to construct the joint.

Table 1 : Fasteners for LOK-KLIP™ installation

KLIP-LOK® 700

NON-CYCLONIC	1 x #12-14x30 Hex head screw on top of bracket
CYCLONIC	2 x #10-16x16 Wafer head screw at each leg of bracket, 2 in total

Installation

Roof design considerations

The roofing sheets should not exceed the maximum recommended end span either side of the LOK-KLIP™ joint. To ensure drainage, refer the table below.

Table 2 Drainage

Purlin Spacing	Minimum Roof Slope
1750mm	1°
1250mm	1.5°
850mm	2°

For advice on roof drainage, refer to the LYSAGHT® roofing & walling installation manual. It may be necessary to employ packers to provide a more gradual change in the slope of the roof.

When specifying or ordering, please refer to the layout schematic detailed below:

Clip layout for KLIP-LOK® 700 with LOK-KLIP™ end joint

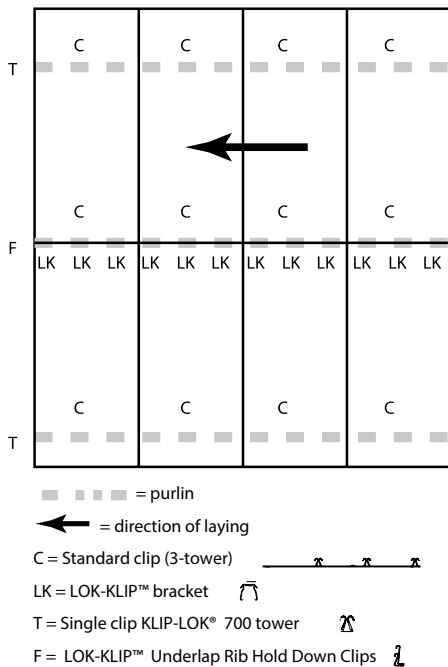

Figure 6: Layout of clips

This layout shows the location and types of clips/brackets required to fit a KLIP-LOK® 700 using LOK-KLIP™ end joint.

Table 3: LOK-KLIP™ Assembly Components

LOK-KLIP™ brackets	43 per 10m
Weather Strip	22 per 10m
LOK-KLIP™ Underlap Rib	1
Hold Down Clips (F) for each finishing end of the LOK-KLIP™ joint	

Turn up and turn down of KLIP-LOK® 700 at LOK-KLIP™ joint

Turning-up

Turn-ups are performed on the upper end of the lower sheets using the turn down tool. Holding the end of the tool against the end of the sheet, pull the handle until the handle bottoms out onto the pan, being careful not to tear the cladding.

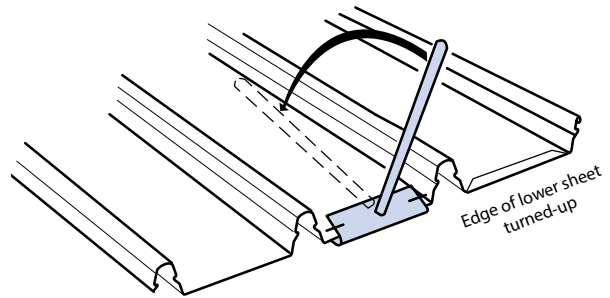

Figure 7: Turn-up of lower sheet of KLIP-LOK® 700 at LOK-KLIP™ end joint.

Turning-down

The upper sheet of a LOK-KLIP™ joint requires the lower end of the upper sheet to be lipped prior to laying the sheets.

- Push the turn-down tool over the end of the tray, as far as it will go.
- Hold the tool hard against the end of the tray and pull the handle until the lipped edge bottoms out on the underside of the pan, resulting in a nominal 20° degrees lip (Figure 7)

Again, be careful not to tear the sheet.

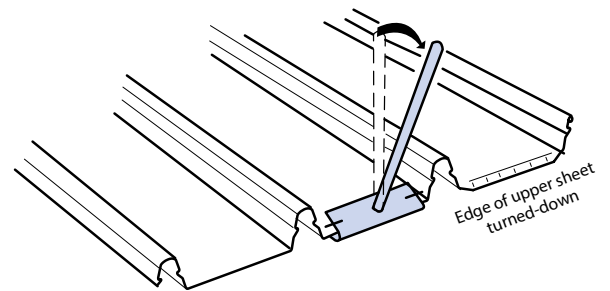

Figure 8: Turning-down the upper sheet at the LOK-KLIP™ end joint.

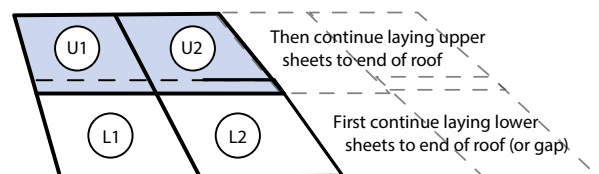

Figure 9: Laying sequence for KLIP-LOK® 700 end joint

Step 1: The installation of KLIP-LOK® 700 should generally be in accordance to the instructions given in the LYSAGHT® roofing and walling installation manual.

Install the lower sheets of the KLIP-LOK® 700 prior to installing upper sheets as per the above sequence. The number of sheets laid will depend upon the site conditions and installer programme. Packers (10mm thick) may be required on the lowest purlin of the upper sheet for roofs of less than 2° slope and less than 1400 mm span. For further information contact your nearest Tata BlueScope Steel office.

Step 2: Turn-up of pans

The pans on the upper end of the lower sheet are to be turned-up as detailed prior to fitting LOK-KLIP™ brackets.

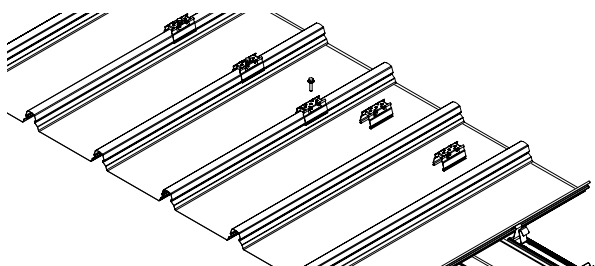

Figure 10: Place LOK-KLIP™ brackets

Step 3: Attach brackets to cladding

Once the required number of lower sheets are installed, position the LOK-KLIP™ brackets on the ribs and fix as detailed in Figures 1 and 5. Use a stringline or straight edge to ensure clips are aligned.

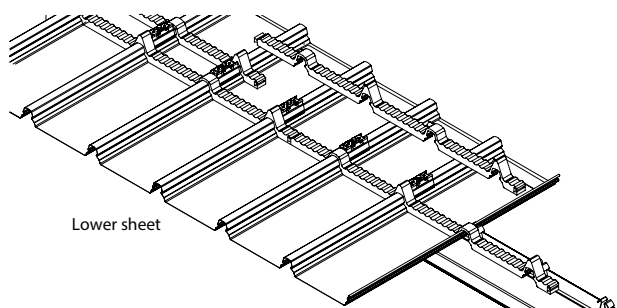

Figure 11: Lay LOK-KLIP™ weather strip either side

Step 4: Place weather strips

Interlocking weather strips are installed on top of cladding so they interlock to similar weather strips each side. The weather strips are placed on both sides and adjacent to the brackets. The joint on the weather strip should not be positioned adjacent to the male leg (underlap rib). Furthermore the two rows of weather strips must have the joint in alternating pans (i.e. the joints are off-set).

Ensure the weather strips properly nest into the 'S' bends of the ribs and this allows for a staggered ventilation path.

Step 5: Lay upper sheet over LOK-KLIP™

Prepare the upper sheets by turning down the pans at the lower end of the sheet as detailed. Position the upper sheets, taking care not to dislodge the previously

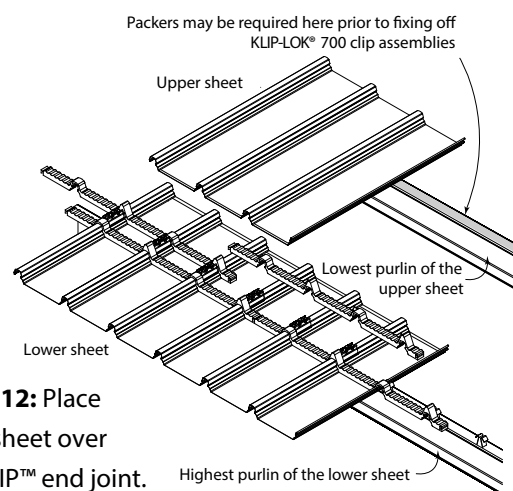

Figure 12: Place upper sheet over LOK-KLIP™ end joint.

installed weather strips.

While standing on the lower sheet, install the upper sheet onto the LOK-KLIP™ brackets by first engaging the inner ribs and then the female side-lap rib (listen for the “snap” engagement). This engagement is done by foot pressure. Ensure correct engagement of the male leg onto the LOK-KLIP™ bracket. Install the remainder of the upper sheet onto the standard fixing clips using the standard process.

Figure 13: LOK-KLIP™ Underlap Rib Hold Down Clips (F)



Step 6: Finishing

Continue the above process to the finishing edge/end of the roof. At the finishing edge of the roof, it is necessary to secure the two underlap ribs using Underlap Rib Hold Down Clips (F) screwed into position. The overhanging weather strips can be cut or torn off. It is now ready to receive barge flashing. Avoid walking at the roof edge.

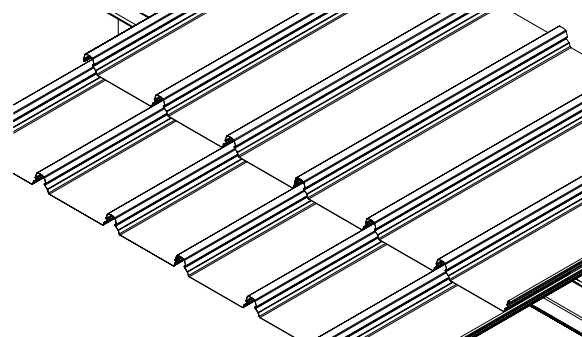

Figure 14: Completed LOK-KLIP™

NOTE: Care should be taken to avoid walking around the LOK-KLIP™ overhang area. Use of LOK-KLIP™ to our guidelines won't void any product warranties.



Global Excellence since 1857

Benefits

- Low profile system maintains clean, long run roof lines of KLIP-LOK® 700
- A cost effective way to achieve a long-length roofing design, even when using shorter roof sheets
- Fast and easy to install – minimal change to current KLIP-LOK® 700 installation practice
- Tested and proven in our NATA accredited testing facility. If installed correctly, will preserve all existing roofing warranties
- Safe and effective weather resistant seal
- Suitable for cyclonic locations
- Allows thermal movement
- No special purlin detailing required - saves time and money
- Fully designed and engineered quality components
- As a stand alone solution, it is compatible with translucent sheeting
- Cost effective for small projects

Product Descriptions

- All descriptions, specifications, illustrations, drawings, data, dimensions and weights contained in this catalogue, all technical literature and websites containing information from LYSAGHT® are approximations only. They are intended by LYSAGHT® to be a general description for information and identification purposes and do not create a sale by description. LYSAGHT® reserves the right at any time to:
 - (a) Supply goods with such minor modifications from its drawings and specifications as it sees fit
 - (b) Alter specifications shown in its promotional literature to reflect changes made after the date of such publication

Disclaimer, Warranties and Limitation of Liability

- This publication is intended to be an aid for all trades and professionals involved with specifying and installing LYSAGHT® products and not to be a substitute for professional judgement
- Terms and conditions of sale available at local LYSAGHT® sales offices
- Except to the extent to which liability may not lawfully be excluded or limited, Tata BlueScope Steel will not be under or incur any liability to you for any direct or indirect loss or damage (including, without limitation, consequential loss or damage such as loss of profit or anticipated profit, loss of use, damage to goodwill and loss due to delay) however caused (including, without limitation, breach of contract, negligence and/or breach of statute), which you may suffer or incur in connection with this publication



360° Solution
Design, Manufacturing &
Construction



Superior Quality
with Unmatched
Performance



Time Tested
Global Legacy



Wide Range to
suit your style



Customer
Centricity



Email us at : lysaght@tatabluescopesteel.com



Tata BlueScope Steel Pvt. Ltd. CIN: U45209PN2005PTC020270
Regd. Office: The Metropolitan, 4th Floor, Final Plot No. 27,
Survey No. 21, Wakdewadi, Shivaji Nagar, Pune - 411005. INDIA.
Tel: +91 20 6621 8000

Website: www.tatabluescopesteel.com

Note:
©2019 Tata BlueScope Steel Pvt. Ltd. All rights reserved. No part of this brochure may be reproduced or transmitted in any form or by any means, electronic or mechanical including photocopy, recording, or any information storage and retrieval system, without permission in writing from Tata BlueScope Steel Pvt. Ltd.. All brand names mentioned in this brochure are registered trademarks of BlueScope Steel Limited under license to Tata BlueScope Steel Pvt. Ltd.*